

500KV FEED CABLE PROJECT FOR EXPO SUBSTATION

Yun **JIANG**¹, Shanghai Municipal Electric Power Company, (China), malan@sh163.net,

Xiaojuan **JIANG**², Zhigang **WANG**², Inspection & Maintenance Company, Shanghai Municipal Electric Power Company, (China), jiang-xiaojuan@163.com, shiboxmb@sina.com,

ABSTRACT

500kV Jing'an (World-Expo) Station had been constructed in downtown of Shanghai by Shanghai Municipal Electric Power Company between April, 2009 and July, 2010. The cable inlets of this substation adopt double circuit of 500kV and 2500 mm² XLPE cable, total lines are laid in cable-dedicated tunnel. The cable circuit is 16km long, including 147 phase joints. Two cable joint structures are selected in this works, with all prefabricated structure and fabricated structure. This paper introduces cable laying, installation of joints, completion test in details, and provides reference and experience for future long-distance, large cross-section 500kV cable construction.

KEYWORDS

500kV cable line, cable laying operation, joint installation, completion test

1 WORKS OVERVIEW

With the rapid development of Shanghai Urban Construction, the load of Shanghai power grid has also increased year by year, to ensure the electricity supply of Shanghai World Expo, 500kV Jing'an (World-Expo) Station had been constructed in downtown of Shanghai. The inlets of this substation adopt triple circuit of 500kV cable, with transmission capacity of 1000MW, 500kV double circuit is constructed in this works, total cable line is laid inside west Beijing road and West China road tunnel, the total length of which is 15.45 km and has set 15 pits, the height of the deepest pit is 27m.

1.1 Cable run

New 500kV XLPE double circuits are put in this works, total lines are laid in cable-dedicated tunnel. The tunnel starts from 500kV World Expo Station at west Beijing road, crosses the downtown above Huangpu river, and connects the cable tunnel of San-lin station.

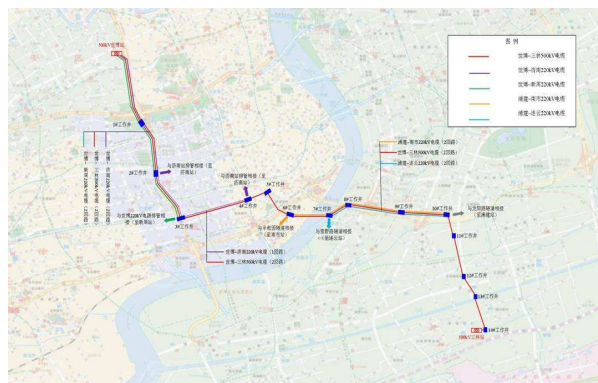

Fig. 1: Sketch map of cable run

1.2 Basic structure of the cable

500kV cable line I has chosen ZRYJLW03-500kV,

1*2500mm² copper conductor, XLPE insulation, smooth aluminum sheath, HFFR outer sheath cross-linked cable produced by the French NEXANS. The outer diameter of cable, insulated outer diameter and the outer diameter of cable are Φ63.7mm, Φ98.5mm, Φ152±3mm respectively. The unit weight and length is 39.5kg/m, 15.615km×3 respectively.

500kV cable line II has chosen ZRYJLW03-500kV, 1×2500mm² copper conductor, XLPE insulation, corrugated aluminum sheath, flame-retardant PVC outer sheath cross-linked cable produced by the Japanese VISCAS. The outer diameter of cable, insulated outer diameter and the outer diameter of cable are Φ61.2mm, Φ97mm, Φ167±3mm respectively. The unit weight and length is 42.6kg/m, 15.657km×3 respectively.

Cable structure and parameters are shown as follows.

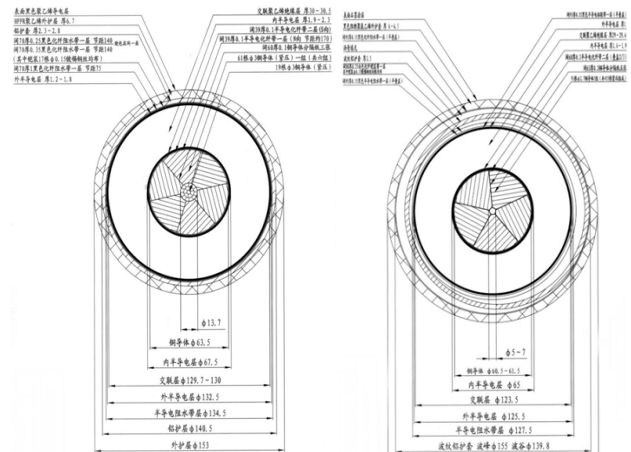

Fig. 2: Sketch map of French Nexans Cable structure, Japanese VISCAS structure (left: NEXANS cable; right: VISCAS cable)

Table1 parameters of French Nexans Cable

Parameters table of performance and structure for 500kV French Nexans Cable			
No.	Content	Unit	Value or description
1	Cable conductor		
	Nominal cross section	mm ²	2500
	Cable structure	—	6 split (the blanks are filled with copper conductors)
	Number of single-wire x diameter of single-wire	Number × mm	61×6×Φ3 (19×Φ3)
	outer	mm	63.5