

DEVELOPMENT OF DRY OUTDOOR TERMINATION WITH SILICONE GEL FOR SELF-STANDING

Anna MORI (1), Shinji MARUICHI (1), Hiroshi NIINOBE (1), Masahiro SUETSUGU (1)

1 - VISCAS Corporation, Ichihara, Japan, a-mori@viscas.com, s-maruichi@viscas.com, h-niinobe@viscas.com, m-suetsugu@viscas.com

ABSTRACT

Insulation oil is generally filled inside bushing of wet type outdoor termination for XLPE cable. But recently, the demand for dry type outdoor termination without using oil is enhanced because it considers environmental aspect. Therefore, a new type dry outdoor termination for self-standing has been developed, which uses own developed silicone gel instead of silicone oil as insulating compound inside the bushing. This paper describes various properties of silicone gel and test results of the developed outdoor termination.

KEYWORDS

dry outdoor termination, silicone gel, self-standing, thermo-mechanical property, XLPE

INTRODUCTION

Insulation oil is generally used for outdoor termination for XLPE cable. In case that a breakdown occurs in porcelain bushing, insulation oil might leak outside and the breaking porcelain shards could cause unexpected damages against nearby equipments. To reduce such risks, several types of dry outdoor terminations using silicone rubber sheds have been recently developed.

As a typical example, flexible termination that mainly consists of silicone rubber unit is widely used over the world since it is useful when directly connecting to overhead line on the mount plate at the tower. However the self-standing performance is still required in many cases. Hence, the flexible termination is not applied for 220 kV class or more due to its low rigidity.

On the other hand, composite bushing that consists of a large epoxy insulator with embedded electrode and silicone sheds has been developed for self-standing dry termination. However such termination needs more components to maintain the interfacial electric

performance with epoxy or XLPE insulation, it has less cost advantage over existing termination.

Therefore, a new dry outdoor termination has developed using silicone gel instead of silicone oil and a hollow composite bushing that consists of FRP and silicone rubber sheds to obtain enough rigidity for self-standing. This paper describes the development mentioned above.

STRUCTURE AND FEATURES

Figure 1 shows the configuration of the 138 kV class self-standing dry outdoor termination. The components are a stress relief cone for controlling electric field, silicone gel (hereinafter referred to as "gel"), and a hollow composite insulator. The basic structure of the termination is almost same with that of existing ones except for the use of gel. The features of the termination are as follows.

- No environmental pollution by oil leakage since gel is used instead of insulating oil.
- No influence caused by breaking porcelain shards in case of breakdown because it uses a hollow composite bushing.
- Easy assembly because of no need to use special tools or skills.

PROPERTIES OF NEW GEL COMPOUND

The gel that is key technology for dry termination is specially blended compound to have been developed through own experimental study. The features of the gel are as follows.

- No special tools are required for injection to the termination.
- Bubbles come out in the gel without using a special defoaming device.

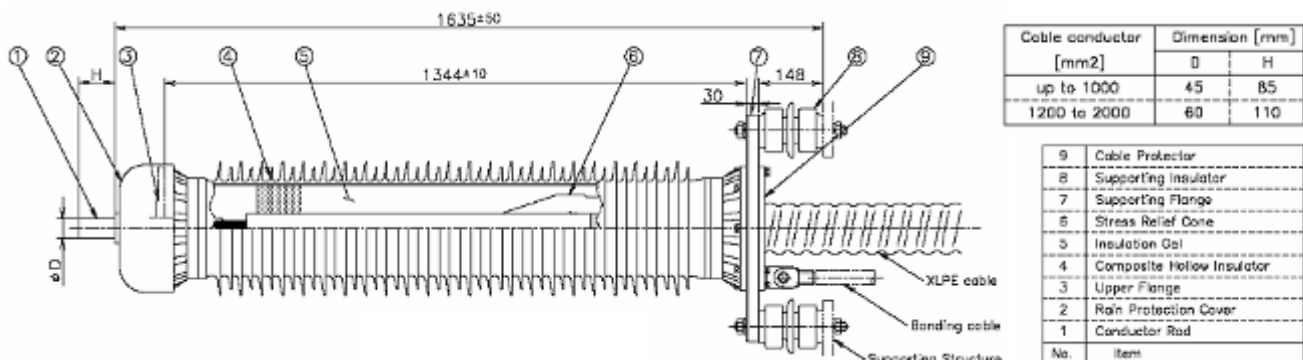

Figure 1: Structure of 138kV class Dry outdoor termination with silicone gel for self-standing