

PARTIAL DISCHARGE (PD) AUTOMATIC DIAGNOSIS TOOL FOR WORKER SAFETY IN UNDERGROUND VAULTS

Lionel REYNAUD, François LÉONARD, Jacques BHERER, Daniel PINEAU, Sylvain POIRIER, Didier MUSSARD, Stéphane GINGRAS, Martin CHARRETTE, Institut de recherche d'Hydro-Québec (IREQ), Canada, reynaud.lionel@ireq.ca, leonard.francois@ireq.ca, bherer.jacques@ireq.ca, pineau.daniel@ireq.ca, poirier.sylvain@ireq.ca, mussard.didier@ireq.ca, gingras.stephane@ireq.ca, martin.charette@ireq.ca

ABSTRACT

The "PD Sniffer" is a first-level tool used by workers to quickly detect partial discharges (PDs) that could be related to a dangerous failure mode in a network accessory. Within a few seconds, hundreds of transitory electromagnetic events are captured and analyzed to give a verdict. If this verdict indicates a possible presence of PDs, a second sensor is connected to the Sniffer to determine the origin of the PDs. Great improvements of the Sniffer are found in the hardware, but major innovations are in the signal processing: the Time Domain Clustering (TDC) and the Phase-Resolved Partial Discharge (PRPD) data mining (PD mining). This paper sets out the principles on which the Sniffer was constructed, explains how it is used by workers and gives some results captured in the field.

KEYWORDS

Partial discharge, medium-voltage, PD mining, time domain clustering, safety, underground.

INTRODUCTION

Hydro-Québec's Partial Discharge Analyzer (PDA) [2] has been used by workers since 2006 to perform preventive maintenance and remove defective components prior to their failure. Diagnosis with the PDA is not fully automatic and requires a final decision to be made by an expert. The overall time from setup to diagnosis is a safety concern when a worker remains inside the vault.

In 2009, Hydro-Québec deployed a PD sniffer capable of delivering an automated diagnosis within 20 s. This new device was designed for use by non-expert workers as a first-level safety tool. When a potential PD is detected by the equipment, the worker exits the vault and calls the PDA/thermograph team.



Fig. 1 - Sniffer probe.

The Sniffer captures hundreds of transitory events at a rate of 1 Gs/s. It groups these events into clusters by finding similar time shapes. It analyzes the resulting cluster signatures in a "relative phase-resolved" diagram identifies the pairs of clusters that have inverse polarities and concludes on the potential presence of a PD.

Grouping into clusters reduces the processing time and increases the signal-to-noise ratio. With the help of PD mining, triggering can be set at a level that picks up PD signals near the noise level or below some other PD

activity levels.

HARWARE AND DATA ACQUISITION

The PD Sniffer is composed of a handle including the start button of the measurement, a telescopic arm and a swivel head (Fig. 1). The head includes a PD receiving antenna, a magnetic sensor for phase-resolved synchronization and a transmitting antenna for self-testing (Fig. 2).

The Sniffer is connected to a controller which selects the filter to be applied for the antenna signal, selects the gain value, fixes the trigger level, and enables the trigger when an expected phase value occurs.

The receiving antenna has a bandwidth of between 5 MHz and 350 MHz. The transmitting antenna is designed to test the chain of hardware and software (not shown in Fig. 2).

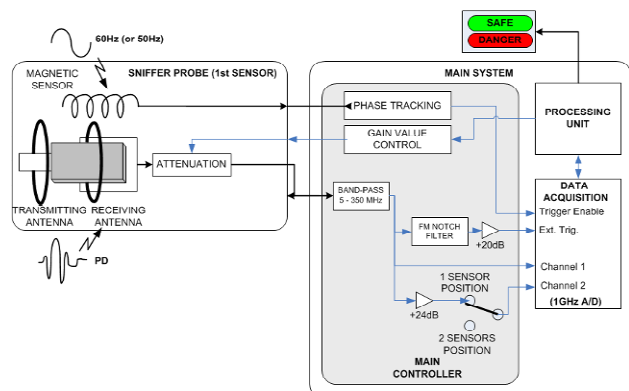

Fig. 2 - Simplified Sniffer hardware schematic.

The trigger enable is synchronized with the phase of the line. At trigger enabling, the maximum number of segments is captured with a fixed maximum period of observation. Since the number of acquired segments is set at a given maximum, any excessive partial-discharge activity leads to the risk of acquisition closing down before it has finished scanning the complete phase cycle. The PD mining principle consists in dividing the cycle into equal sections and setting a maximum number of segments per section that will ensure the entire cycle will be scanned [1].

When an FM signal disturbs the measurement, the controller switches to an external trigger connected to the antenna through a notch filter (100 MHz). The numerical conversion of the signal uses the two available channels on two 8-bit scales. This parallel conversion accelerates the measurement process and increases to 12 bits the effective input dynamic.

When used alone, the Sniffer can detect a PD, but provides no information about its origin. To confirm the