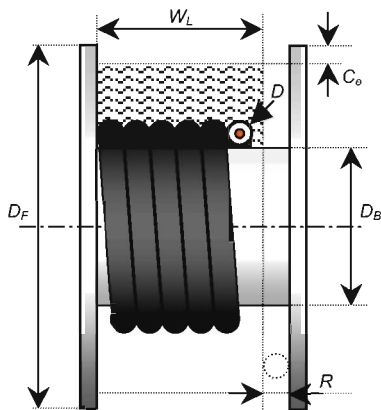

**A.10.6.****Increasing cable drum lengths**

LESUR F., EDF R&D, Moret-sur-Loing, France
 ARGAUT P., SACHER J., SAGEM, Montereau, France

maximising cable drum lengths is mainly to reduce the number of joints. Increasing length can be achieved in reducing the cable outer diameter or improving the winding capacity of the drum. The paper presents some means to carry it out and the consequences on the design of an underground power link and its operating conditions.

Keywords: delivery length, drum.

1. Design parameters of a drum

- D_B : drum barrel diameter,
- D_F : drum flange diameter,
- W_L : winding permissible width,
- C_e : external clearance,
- R : ramp,
- D : cable outer diameter.

A ramp, of equivalent width of the cable outer diameter, is sometimes arranged in order to take the cable end out for routine-test. Another space is kept, the external clearance, between the last layer of the cable corona and the overall diameter of the drum flanges.

The hatched area corresponds to the available volume to wind the cable turns and layers.

l'augmentation des longueurs livrables sur touret réside principalement dans la réduction du nombre de jonctions. L'augmentation de la longueur s'obtient en réduisant le diamètre externe du câble ou en augmentant la capacité de charge du touret. L'article présente des moyens susceptibles d'y parvenir et les conséquences sur le dimensionnement d'une liaison souterraine et son exploitation.

Mots clés : longueur livrable, touret.

Note: All diagrams are drawn with disproportional values of cable and barrel diameters, in order to point out the cable path. A common ratio would be $D_B \approx 20 \times D$.

Before any calculation, it is wise to take into account a tolerance on cable diameter (a few per cents added to nominal value), and a coiling allowance (for unwanted gaps between adjacent turns).

2. Approximate method of cable drum length calculation

The different turns and layers of the cable are identified with contiguous stacked tores. The whole cable length is equal to the sum of each tore length.

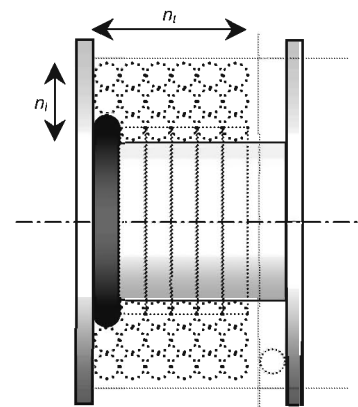

- n_t : number of turns in a cable layer,
- n_l : number of layers.