

## EFFECTS OF CROSS-LINKING TEMPERATURE ON INSULATION PROPERTIES OF CROSS-LINKED POLYETHYLENE

Xiao-hui ZHU, Feng-zheng ZHOU, Zheng-zheng MENG Tianjin Electrical Power Research Institute, Tianjin 300384, China., zhuxiaohui888@126.com, zhoufengzheng@hotmail.com, mzheng123@gmail.com

### ABSTRACT

In this paper, cross-linked polyethylene (XLPE) was employed as test sample to investigate the effect of cross-linking Temperature on the insulation properties. Dielectric breakdown as well as space charge dynamics of the sample was examined by means of withstand-voltage/hold-off time and surface potential decay test respectively. Fourier transform infrared spectrum and differential scanning calorimetry (DSC) were also performed with the purpose of understanding the change of chemical structure in response to the variation of cross-linking methods. Obtained results show that with the increase of the cross-linking temperature, the breakdown voltage/hold-off time firstly increase then tends to decrease, whilst the decay rate of space charge decrease initially then appears to increase. It is suggested that the alteration of the insulation properties is closely related to the change of chemical structures and crystallinity those are varied as a function of cross-linking temperature.

### KEYWORDS

XLPE; Dielectric Breakdown; Cross-linking Temperature; By-products; Crystallinity.

### 1 INTRODUCTION

This paper presents investigations aimed at clarifying the effect of cross-linking temperature on insulation properties of XLPE. Obtained results show the dependence of dielectric breakdown as well as charge dynamic behaviors upon the temperatures, and such dependence is attributed to the variation of crystallinity and chemical structures of the insulation.

### 2 EXPERIMENTAL SETUP

#### 2.1 Sample Preparation

Super-clean grade LDPE was employed as the base material, the density of which is ranged from 0.910~0.925 mg/mm<sup>3</sup>. By adding 2% DCP as cross-linking agent and 0.2% antioxidants (300 #) into LDPE, bullets of such mixture were produced by auto-metering twin-screw extrusion equipment. Subsequently, the bullets were placed in a hydraulic press machine at 115 °C for 10-minute preheating without any pressure, after which the cross-linking was performed at 150 °C, 160 °C, 170 °C, 180 °C, 200 °C and 220 °C for 5 minutes with pressure of 15 MPa, respectively. Then the samples were cooled naturally to ambient temperature under the same pressure. The thickness of the sample was 1 mm. Before the test, the sample was wiped with ethyl alcohol and dried in a desiccator at room temperature for 24 hours.

#### 2.2 Surface Potential Decay Test

Surface potential decay has been proven a powerful tool for investigating space charge dynamics. The following procedures were accomplished so as to perform the

surface potential decay test. Firstly, corona charging method was employed to introduce electrical charges on the sample surface. The electrode arrangement and test circuit were shown in Fig. 1. The diameter of the needle electrode was 1 mm and with curvature radius in tip of 12.5 μm. The grid electrode was used to control the surface potential, and the back electrode was grounded. The interval between the needle tip and the grid electrode was 5 mm, while the distance between the grid and the sample surface was 8 mm.

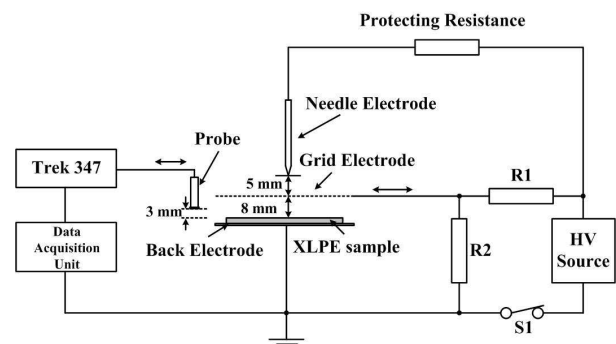

Fig.1 Schematic diagram of electrode arrangement and test circuit

The experiment was carried out at 35 °C with relative humidity of ~ 45%. By applying DC voltage of ±5 kV between the needle-plate electrode for 5 minutes, corona discharge around the needle tip was induced. The surface potential was controlled by the grid electrode to ~ ±1.3 kV. During the charging period, the probe was placed ~15 cm away from the sample surface to avoid discharge between H.V. electrode and the probe tip. After S<sub>1</sub> was switched off and a subsequent 3-minute standing of the sample, surface potential was recorded by placing the probe 3 mm above the surface center, and the probe was connected to an electrometer TreK 347. Accordingly, the decay behavior of the potential was plotted. Mean decay rate of the charge was calculated. In this paper, the mean decay rate was defined as the reduction of normalized surface potential per hour in the first 20 hours. Thus, the rate for sample cross-linked with 150 °C, 160 °C, 170 °C and 180 °C was obtained respectively.

#### 2.2 Dielectric Breakdown Test

Electrode arrangement and test circuit were shown in Fig. 2. The diameter of the needle electrode was 2 mm and with curvature radius in tip of 12.5 μm. The diameter of the back electrode was 25 mm with width of 100 μm. The needle electrode was connected with high voltage, while the back electrode was grounded. The electrode and test sample were placed in insulating oil to prevent surface discharge or corona.