

# The Use of Life Cycle Cost Analysis to Determine the Most Effective Cost of Installation 500 kV of Java-Sumatra Power Interconnection System

Herry NUGRAHA, Zivion SILALAH; PLN Indonesia, Bandung Institute of Technology, Indonesia, herry.nugraha@gmail.com, zivionsilalahi@yahoo.com  
Ngapuli SINISUKA; Bandung Institute of Technology, n\_sinisuka@yahoo.com

## ABSTRACT

In order to transfer 3,000 MW capacity of the electricity from the Mine-Mouth Coal-fired Power Plants in South Sumatra to the load center in Java, PLN Indonesia intends to build the Java-Sumatra Power Interconnection System. The scopes of these works of the Power Interconnection System are including: HVAC 500 kV Transmission Line in Java, HVAC 500 kV Transmission Line in Sumatra, HVDC 500 kV Transmission Line in Java, HVDC 500 kV Java-Sumatra submarine cables. This paper will analyze the financial feasibility study to ensure if the project has economic benefit, and the asset would be used effectively and efficiently along its benefit period using Life Cycle Cost Analysis (LCCA). In this paper, a LCCA will be simulated to analyze three alternatives and to decide which alternative is the most profitable. Cash Flow and Monte Carlo simulations for a period of 30 years operation of the Interconnection System are part of the LCC models to achieve the objectives of this paper.

## KEYWORDS

Life Cycle Cost Analysis; LCCA; Java-Sumatra 500kV DC; Power Transmission Submarine Cables; Monte Carlo.

## 1. INTRODUCTION

Electricity in Indonesia is currently experienced a rapid development along with the high growth in industry as well as residential demand. The characteristic between one area to another is significantly different. In Java as most populated island, 2000 MW of electric power need to be added to meet the increasing demand. Most of the major power plants are using coal as the energy source. In order to supply this energy, most of the coals are transported from other islands (Sumatera and Kalimantan). These schemes are considered to have many disadvantages, such as the high transportation cost, and also the limitation caused by the fluctuation of weather condition.

Regarding to this issue, the Java-Sumatra HVDC Interconnection System is now under construction in order to transfer power from Mine-Mouth Coal-fired Power Plants at South Sumatra to the load center in Java. The scopes of these works of the Power interconnection system are including: HVDC 500 kV transmission line in Sumatra, and HVDC 500 kV Java-Sumatra submarine cables, HVAC 500 kV transmission line in Java, HVAC 500 kV transmission line in Sumatra, HVDC 500 kV transmission line in Java,. Configuration of this system is provided in figure 1.

In Java-Sumatra transmission (especially in the HVDC sequence), several configuration can be designed regarding to the engineering and economic issues.

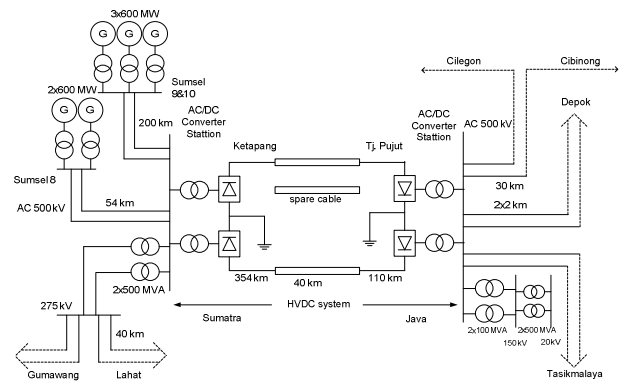

Fig.1: Configuration of Java-Sumatra HVDC Interconnection System

In this paper, it will be discussed how to calculate and chose the most effective cost of Java-Sumatra Power Interconnection System. The scopes of these works of the Power Interconnection System during its life cycle (LCC). The objective of the LCC is to choose some alternatives of the most cost effective approach to determine the lowest long term cost of ownership [6].LCC is the total cost of ownership including the cost of the project or asset acquisition, operation & maintenance, and disposal. LCC includes both deterministic costs (such as acquisition costs, yearly maintenance costs and disposal costs) and probabilistic costs (such as the cost of failure, repairs costs, and energy not served (ENS)). Most of the probabilistic costs associated directly with the reliability and maintenance characteristics of the system. Monte Carlo simulation techniques are used to join probability chance for failure, probability of ENS and economic data to solve problems of uncertainty. Failure costs FC are incurred by each year as they fail using a Monte Carlo simulation of failure or success to cover the uncertainty.

## 2. METHODS

### 2.1 Life Cycle Cost

The method which will be discussed in this paper includes the scenario of the design decision; parameter of performance; risk calculation; and computation of all associated costs of capital, maintenance and failure costs based on the probability of chance for failure. The method is proposed to analyze failure data using appropriate cost profile in order to represent the fact that each scenario of design and each failure have different prices, in different time periods at an economic cycle. These steps can be described briefly as follows:

1. Specify scope, boundaries, environments and functions.