

Impact of cable modeling in electromagnetic transient simulations of MVDC systems

Amjad Mouhaidali, Silvain Marache, Piotr Dworakowski, Martin Henriksen, Leo Dalmar; SuperGrid Institute (Villeurbanne, France), amjad.mouhaidali@supergrid-institute.com, sylvain.marache@supergrid-institute.com, piotr.dworakowski@supergrid-institute.com, martin.henriksen@supergrid-institute.com, leo.dalmar@supergrid-institute.com

ABSTRACT

This paper explores how choice of the cable system model may impact the simulated electromagnetic transient response of an MVDC system under fault situations. Simulations are carried out in MATLAB/Simulink environment, allowing for a detailed AC-DC converter model, necessary for accurate transient analysis. A state-of-the-art review of the existing and relevant cable models is presented. Three models are chosen to be implemented: the PI model, the constant parameters (CP) and the universal line model (ULM) also known as the wide band (WB) model. The simulation results present the transient overvoltage and current responses including the cable screen current. Illustrative results are provided to show the importance of transmission line model choice.

KEYWORDS

Cable modelling, power converters, electromagnetic transient, overvoltage.

INTRODUCTION

As the usage of high-voltage direct current (HVDC) grows, so does the popularity of medium-voltage direct current (MVDC) systems. The benefits of MVDC can be analyzed in terms of energy efficiency, power dispatch, power capacity, power supply range, raw material consumption CO2 emissions, network resilience and ancillary services to the AC grid [1][2][3].

The emergence of MVDC systems relies on the development of electric components including power electronic converters, DC switchgear and DC cables. The requirement for these components depends on the MVDC system architecture, control, and protection. Adequate electromagnetic transient simulation models are necessary to establish some of the requirements. Electromagnetic transient simulations (EMT) are a go-to for analyzing MVDC systems, and cable modeling forms a crucial part of such simulations. If the cable modeling isn't precise, it could significantly impact the simulation results and the performance of the MVDC system overall.

This article will first provide the test case to be studied and an overview of the different cable models used in EMT simulations. The article will then present the different components of the MVDC systems. Finally, the article will present the results of simulations performed using different cable models and conclude by summarizing the impact of cable modeling on the accuracy of EMT simulations of MVDC systems.

MVDC NETWORK ARCHITECTURE

The architecture of the case study MVDC system is presented in Figure 3. The ratings of the analyzed MVDC network are summarized in Table 1, according to [4]. The interface with the AC grid is ensured by an AC-DC station with a voltage source converter (VSC) and a transformer. A DC-DC converter is considered to interface the LV DC load/source. The grounding is realized on the DC side, at the connection of two converters, the value of the grounding resistance is equal to 1Ω. The protection equipment is not analyzed in this paper.

AC-DC STATION

The AC-DC station between the AC grid and the MVDC network is composed of a 3-winding transformer and a 3-level Neutral Point Clamped inverter (NPC), which topology is presented in Figure 1. Comparing to 2-level inverters, the NPC synthesizes AC voltages from DC voltage using extra voltage level through the connections to the point Z presented in Figure 1.

DC-DC STATIONS

The DC-DC station insures the connection between LVDC loads or sources and the MVDC collector network. In this study, converter based on medium frequency transformers (MFT) are considered. A general representation of this type of converter is shown in Figure 2.

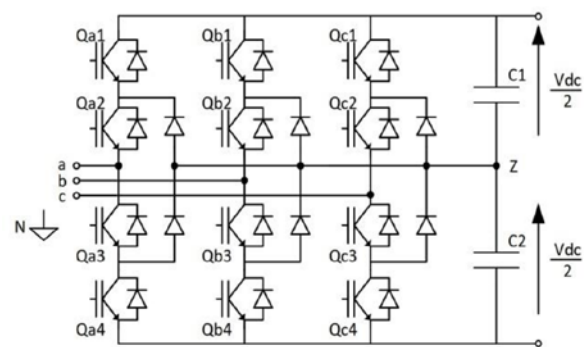

Figure 1: Topology of a 3-level Neutral Point Clamped inverter (NPC)

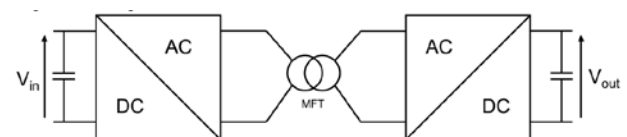

Figure 2: General diagram of an isolated, bidirectional power flow DC-DC converter